

BIRRANA DRIVE WHEEL END INSTALLATION TO SUIT CAT 785 TRUCK

Most accidents involving machine operation or maintenance are caused by failure to observe basic safety rules or safety precautions. Read and understand all safety precautions and warnings, before attempting installation and operation of this component.

Birrana Engineering cannot anticipate every possible circumstance that may involve a potential hazard. You must comply with all mine-specific safety procedures, and satisfy yourself that any procedure, tool or operation method used is safe for yourself and others.

Refer to the truck manufacturer's repair and maintenance instructions in conjunction with these instructions where applicable. Obey all recommended safety instructions or warnings.

Before working on any equipment make sure that the work area is safe, and that the equipment is tagged and locked out in accordance with mine safety procedures.

1. Flush all brake lines with a strong solvent to remove brake material and debris.

2. Clean out the hydraulic brake reservoir tank and clean the screens.

3. Rekit or fit an exchange roto chamber and slack adjustor.

4. If the **A6982 Birrana isolation seal** has been supplied, ensure that the isolation seal breather is located near top dead centre, as per the sketch below. Please note that the breather may not be correctly aligned, as the orientation of the breather is different on left and right hand wheel ends. Check that the hole in the steel spacer plate fitted behind the isolation seal is aligned with the breather. Using Loctite 262 torque bolts to 47Nm (35 ft/lbs).

5. Install the wheel speed sensor using the adjustment procedure found in SENR2986 Automatic Electronic Traction Aid Service Manual. Ensure that the connector is lockwired in place after assembly.

6. Thoroughly clean all mounting surfaces and check for burrs before installing the wheel group. Ensure that all rust inhibitor is removed from the wheel studs and the wheel flange to allow for proper torque on the hex nuts and wheel studs.

7. Fit o-ring to spindle register. Grease may be used to hold the o-ring in place if required. Do not get grease on spindle mounting face.

8. If the **A6982 isolation seal** is fitted, lubricate the inside of the rubber seal ring with oil or petroleum jelly (Mobil 'Waxrex 511 White' or similar).

9. Fit the wheel end, and torque all mounting bolts to specification.

10. Install the traction aid sensor guard with appropriate spacers.

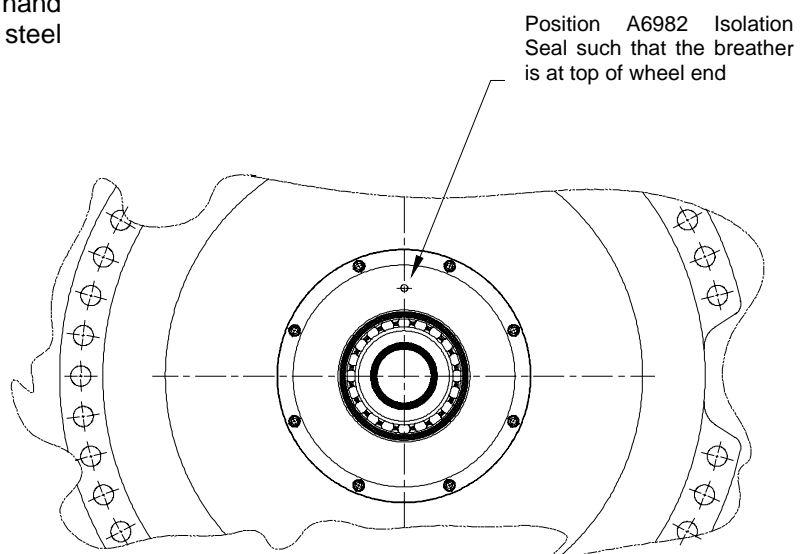

Figure 1

11. Inspect all oil lines for serviceability and cleanliness prior to use and fit brake fittings from the former wheel end. Use new o-ring seals on all fittings and connect the lines and hoses to the rear brake.

12. Check that the AETA drive collar clamp (6G0971) is fastened and staked at 1318mm (51.9") from the end of the half shaft so it will be aligned with the sensor.

13. Remove the final drive cover.

14. If the **A6982 isolation seal** is fitted, apply oil or petroleum jelly (Mobil 'Waxrex 511 White' or similar) liberally to the end of the half shaft.

15. Insert the half shaft ensuring that the drive collar clamp is aligned with a notch in the traction aid ring (6G0969). Note that when an isolation seal is fitted there are two less useable notches in the traction aid ring. See figure 2.

16. When the half shaft reaches the seal ring, some extra force will be required to force the shaft through the seal. Once through, the shaft should slide easily until located in the differential. At this point the drive collar should also locate within the traction aid.

17. Install final drive cover. Apply Loctite 262 and torque bolts to 122 Nm (90ft lbs).

18. Refill the axle housing and wheel end(s) separately with appropriate oil.

19. Install the rims and tyres and check that the tyres are inflated to the appropriate pressure.

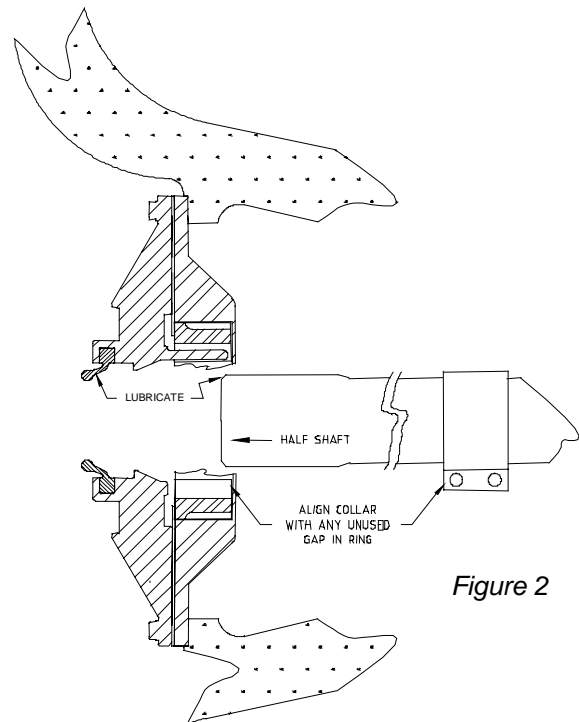

Figure 2

20. Ensure that there is no tyre contact on the rock ejector.

21. With the temperature of the brake cooling oil between 79°C and 93°C, check the brake inlet cooling pressure. With the engine at low idle the pressure must not be below 2psi (14kPa), and at high idle must not be above 25psi (172kPa). If the pressure is exceeded, seal damage will result.

*If you require any further assistance with this procedure please contact your local Birrana representative.
Adelaide (08 8445 7755) Perth (08 9370 5048) Mackay (07 4952 5422) Singleton (02 6571 4488)*