

BIRRANA A7032 DIFF / PLANETARY ISOLATION SEAL TO SUIT CAT 789 TRUCK

Most accidents involving machine operation or maintenance are caused by failure to observe basic safety rules or safety precautions. Read and understand all safety precautions and warnings, before attempting installation and operation of this component.

Birrana Engineering cannot anticipate every possible circumstance that may involve a potential hazard. You must comply with all mine-specific safety procedures, and satisfy yourself that any procedure, tool or operation method used is safe for yourself and others.

Refer to the truck manufacturer's repair and maintenance instructions in conjunction with these instructions where applicable. Obey all recommended safety instructions or warnings.

Before working on any equipment make sure that the work area is safe, and that the equipment is tagged and locked out in accordance with mine safety procedures.

1. If the spindle has been previously fitted with an oil recirculation system, ensure piping has been removed, and a block has been fitted to the gap in the T.A. mount flange in the spindle. Refer to Birrana Engineering for more details.
2. Position the isolation seal with the breather located near top dead centre (see Figure 1). Check that the hole in the steel spacer plate fitted behind the isolation seal is aligned with the breather. Using Loctite 262 torque bolts to 47Nm (35 ft/lbs).
3. Install the wheel speed sensor using the adjustment procedure found in SENR2986 Automatic Electronic Traction Aid Service Manual. Ensure that the connector is lockwired in place after assembly.

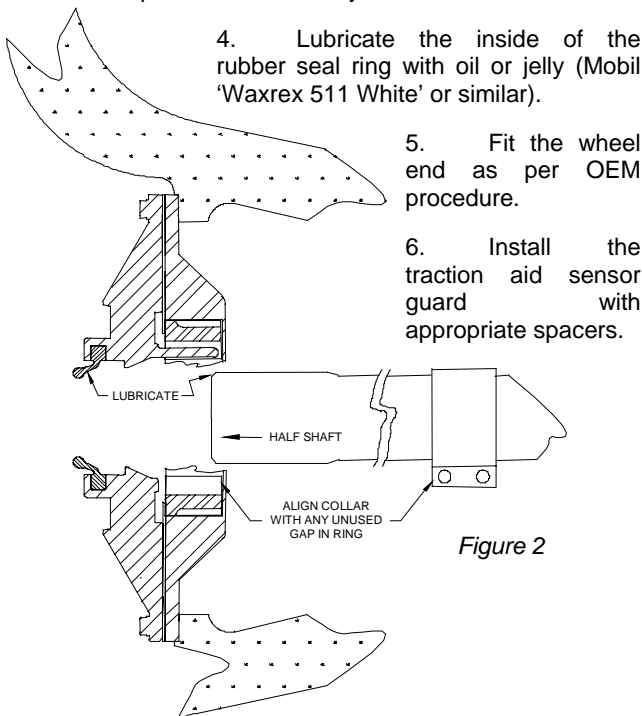

Figure 2

7. Check that the AETA drive collar clamp (8W8743) is fastened at 1550mm (61.0") from the end of the half shaft so it will be aligned with the sensor.
8. Remove the final drive cover.
9. Apply oil or petroleum jelly (Mobil 'Waxrex 511 White' or similar) liberally to the end of the half shaft.
10. Insert half shaft ensuring that the drive collar clamp is aligned with a notch in the traction aid ring (8W8744). Note that when an isolation seal is fitted there are two less useable notches in the traction aid ring (see Figure 2).
11. When the half shaft reaches the seal ring, some extra force will be required to force the shaft through the seal. Once through, the shaft should slide easily until located in the differential. At this point the drive collar should also locate within the traction aid.
12. Complete reassembly of wheelend, and fill the planetaries and differential with oil to the correct level.

NOTE

The oil in the planetary and differential will have to be filled and level-checked separately after installation of the seal assembly.

Position the A7032 Isolation Seal such that the breather is at top of wheel end

Figure 1

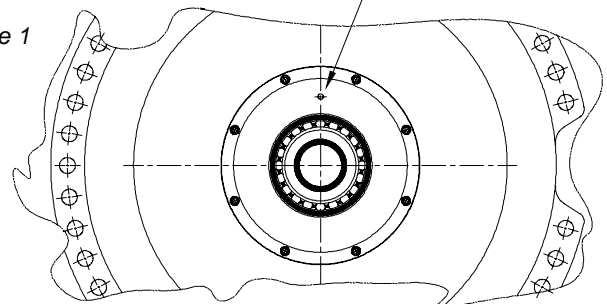

If you require any further assistance with this procedure please contact your local Birrana representative.
Adelaide (08 8445 7755) Perth (08 9370 5048) Mackay (07 4952 5422) Singleton (02 6571 4488)