

BIRRANA A4475 DIFF / PLANETARY ISOLATION SEAL TO SUIT 776 / 777 TRACTOR & TRUCK

These instructions are a recommended fitting procedure to be used in conjunction with usual sound fitting practices. Please read through these instructions before attempting installation.

Refer to the relevant section of the machine manufacturers' maintenance manual and obey all recommended safety instructions or warnings.

Before working on any equipment make sure that the work area is safe, that the equipment is tagged and locked out in accordance with mine safety procedures, and that the machine is safely supported by stands of suitable capacity.

1. Remove the final drive planetary and halfshaft. Remove the wheel bearing retainer plate. It is not necessary to remove the ring gear / anchor hub assembly or the wheel assembly, but ensure that they are supported or restrained so that the working environment is safe.
2. Ensure that the bore in the spindle end has been machined as per Figure 1 on the following page. In addition, ensure that the bore in the spindle end is clean and free from damage, sharp edges or burrs.
3. Lubricate the spindle bore and the 'O'-rings on the outside of the isolation seal assembly with oil.
4. Orient the isolation seal breather to the top of the spindle. Push the isolation seal assembly into the spindle bore. A rubber hammer may be used with caution to aid installation. Once installed, the 'O'-rings on the outer portion of the isolation seal assembly should restrain the outer portion from rotation. The inner portion should be free to turn.
5. Refit the shim stack and wheel bearing retainer as per usual procedure. It is recommended that new retainer bolts be used. If the wheel bearings have not been disturbed, it should be possible to re-use the original shim stack.
6. Lubricate the halfshaft and the rubber element in the isolation seal assembly with oil, and push the halfshafts through the rubber element. Considerable force may be required. Before engaging the inner shaft spline into the differential side gear splines, check that the inner portion of the isolation seal assembly rotates with the shaft.
7. Complete reassembly of the wheelend, and fill the planetaries and differential with oil to the correct level.

Note: Incorrect assembly of the halfshaft may damage the rubber element. By feeling with a blunt instrument around the face of the rubber element (through the gap between the retainer plate and halfshaft), it should be possible to determine if any tears are present.

Ensure that the seal assembly does not protrude past the end face of the spindle.

Ensure that the breather is orientated to the highest point.

NOTE

The oil in the planetary and differential will have to be filled and level-checked separately after installation of the seal assembly.

If you require any further assistance with this procedure please contact your local Birrana representative.

Adelaide (08 8445 7755) Perth (08 9370 5048) Mackay (07 4952 5422)

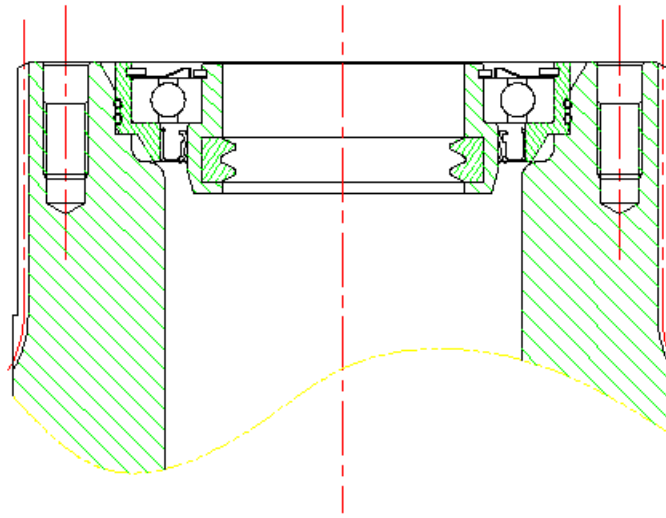

FIGURE 2.

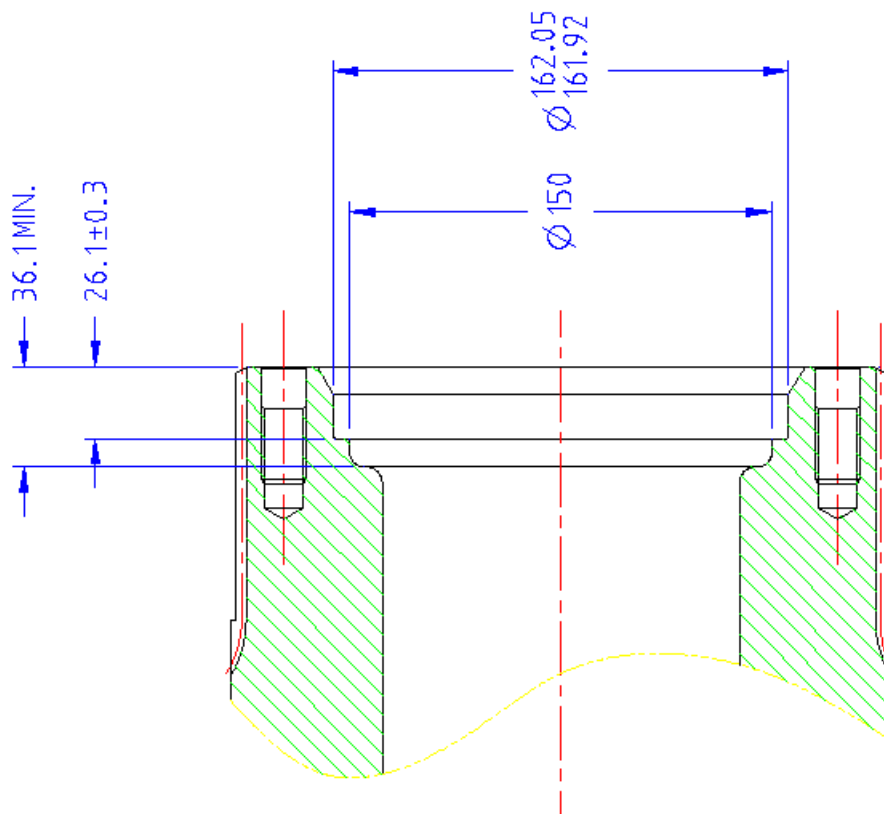

FIGURE 1.