

BIRRANA A8728 BRAKE WEAR GAUGE TO SUIT CAT TRUCKS – 785 REAR BRAKE, 793 FRONT BRAKE

Most accidents involving machine operation or maintenance are caused by failure to observe basic safety rules or safety precautions. Read and understand all safety precautions and warnings, before attempting installation and operation of the brake wear gauge.

Birrana Engineering cannot anticipate every possible circumstance that may involve a potential hazard. You must comply with all mine-specific safety procedures, and satisfy yourself that any procedure, tool or operation method used is safe for yourself and others.

Refer to the truck manufacturer's repair and maintenance instructions in conjunction with these instructions where applicable. Obey all recommended safety instructions or warnings.

Before working on any equipment make sure that the work area is safe, and that the equipment is tagged and locked out in accordance with mine safety procedures.

The Birrana brake wear gauge is a tool for measuring brake wear, and remains in the wheel end at all times. It is completely oil sealed, and eliminates the need for bleeding the brakes when checking brake wear.

In addition, the Birrana brake wear gauge can be set to a pre-determined wear condition – ie 0% wear on a new brake pack. This ability to set the brake wear gauge eliminates the build-up of manufacturing tolerances, which allows far more accurate measurement. The procedure to set the gauge is contained within this document.

Once the Birrana brake wear gauge has been set, only a single reading or measurement is required to check wear.

CAUTION

Use of the Birrana brake wear gauge does not eliminate the need to conduct regular braking performance checks, e.g. "drive-through" tests. All manufacturer's brake inspection and testing procedures, plus any mine specific, regulatory or statutory inspection and testing requirements must continue to be followed.

CHECK FIT OF GAUGE IN BRAKE HOUSING

(Check to be carried out before reassembly of brake group, with housing stripped from brake)

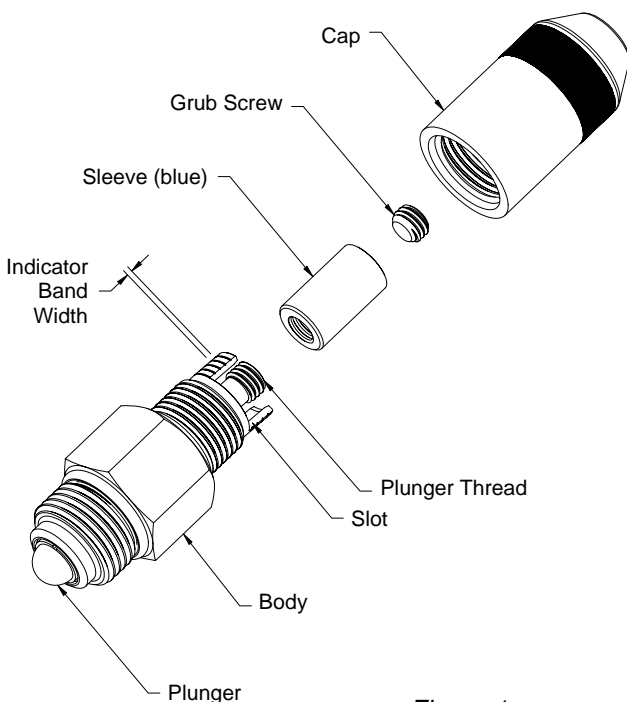

Figure 1

Note: Due to the variance in brake housings, it is possible that the brake wear gauge plunger may interfere with the brake housing port it is installed into. Therefore, it is important to ensure that the plunger can fully and freely extend through both ports it can be installed into.

1. Unscrew the plugs in the brake housing ports labelled 'S'.
2. Remove the cap from the brake wear gauge.
3. Ensure that the plunger can fully extend. The sleeve may need to be wound out.
4. Screw the brake wear gauge into one of the ports labelled 'S'.
5. Depress the brake wear gauge sleeve, to extend the plunger through the port. If the plunger or circlip contacts the brake housing, the port will need to be drilled out as detailed in "Drill Out Port". Unscrew the brake wear gauge.
6. Repeat steps 4 – 5 for the second port.
7. If the plunger and circlip do not hit the housing in either port, proceed to "Measure Plates".

DRILL OUT PORT (IF REQUIRED)

1. Screw the B8099 drill bushing into the selected port.
2. Drill the brake housing using a ½” drill, and the B8099 drill bushing as a guide.
3. Unscrew the B8099 drill bushing.
4. Ensure that the port is free from burrs and swarf.

MEASURE PLATES

1. Measure the thickness of the friction discs.

Table 1

Friction Disc Wear Chart	
Disc Thickness	Percent Disc Worn
5.08mm (0.200")	0%
5.03mm (0.198")	10%
4.98mm (0.196")	20%
4.93mm (0.194")	30%
4.88mm (0.192")	40%
4.83mm (0.190")	50%
4.78mm (0.188")	60%
4.72mm (0.186")	70%
4.67mm (0.184")	80%
4.63mm (0.182")	90%
4.57mm (0.180")	100%

2. Replace any discs that do not have the necessary thickness to last until the next scheduled brake rebuild.

The difference between the thickest and thinnest friction disc should not be greater than 0.1mm.

3. Replace any discs that exhibit signs of overheating, water damage, spline damage or cracking.
4. Replace any stationary plates that are thinner than 2.29mm.
5. Replace any stationary plates that have deep radial grooves, or are warped.
6. Replace both of the dampers.
7. Add up the thicknesses of all the friction discs. Record the overall width of the friction disc stack.

INSTALL AND “ZERO” THE GAUGE

1. Having ensured that the previous steps have been completed, assemble the brake as per CAT or Birrana specification.

CAUTION

The Brake Wear Gauge must be adjusted at the time of installation, to suit the actual brake port in which it will be used. Screwing the device into another port or using an incorrectly “zeroed” gauge may lead to incorrect wear measurements being made.

WARNING

If the Brake Wear Gauge installation is done with the wheel group on the truck:

- **Ensure the truck park brakes are applied, and chock the truck wheels.**
- **Isolate and lock-out the truck, in accordance with mine safety procedures.**
- **Do NOT activate the service brakes or retarder at any point until Brake Wear Gauge installation has been completed.**

2. Remove the cap from the brake wear gauge. Loosen the grub screw, and wind the sleeve out (ACW), until the plunger thread is just visible below the sleeve.

CAUTION

Ensure the sleeve is blue in colour. If the sleeve is not blue, the gauge may be intended for use with a different brake group, and could lead to incorrect wear measurements being made.

3. Screw the brake wear gauge into the selected port labelled ‘S’ (lower port, normally fitted with a plug), **which has been checked for clearance earlier (see “Check Fit of Gauge in Brake Housing”)**.
4. With the park brakes applied (ie no hydraulic pressure in the park brake release cavity), depress the sleeve to contact the plunger with the brake piston.

5. Whilst depressing the sleeve, screw in the sleeve to achieve the correct setting (use Table 2 as a guide).
6. Hold the sleeve to prevent it from turning, and “nip-up” the grub screw with a 1/8” allen key.
7. Double check the setting of the sleeve. If not correct, loosen the grub screw, then repeat steps 5 - 7.
8. Unscrew the brake wear gauge from the brake housing.

WARNING

Do NOT activate the service brakes or retarder when the brake wear gauge is removed. Potentially hot oil may be expelled, which may cause burns or personal injury.

9. Depress the sleeve to expose the flats on the plunger. Refer to Figure 3. Put a 8mm (5/16”) spanner on the flats of the plunger. Using the spanner and allen key, tighten the grub screw to secure the sleeve in place.
10. Screw the brake wear gauge back into the brake housing.
11. Double check the setting of the sleeve. If not correct, loosen the sleeve and grub screw, then repeat steps 5 - 11.
12. Screw on the cap by hand. Do not overtighten.

Note: An optional guard B8499 is available and may be fitted to provide additional mechanical protection of the device.

13. The guard may be fitted as illustrated in Figure 4. Replace the washer and nut, and tighten nut to a torque of 875Nm (645 ft.lb)
14. Bleed the service brake as per manufacturer’s instructions.

Table 2 – 785 Rear & 793 Front

Friction disc stack height - See Step 7 of “Measure Plates”	Percent brake wear remaining	Height from sleeve to bottom of slot
50.80mm	100%	5.9mm [†]
50.29mm	90%	5.3mm
49.78mm	80%	4.7mm
49.27mm	70%	4.1mm
48.76mm	60%	3.5mm
48.25mm	50%	2.9mm
47.74mm	40%	2.4mm
47.23mm	30%	1.8mm
46.72mm	20%	1.2mm
46.21mm	10%	0.6mm
45.70mm	0%	0.0mm

[†]Set the sleeve flush with the top of the gauge castellations, when new plates are fitted.

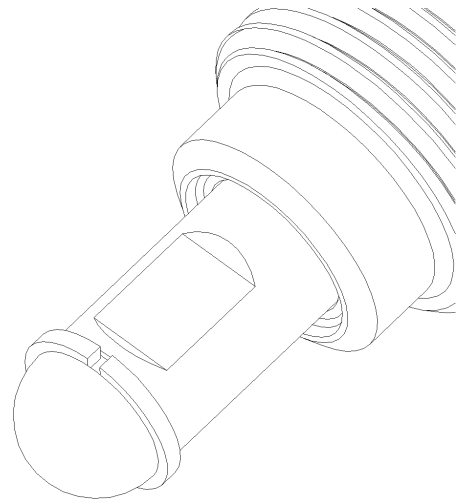

Figure 3



Figure 4

USING THE GAUGE TO MEASURE BRAKE WEAR

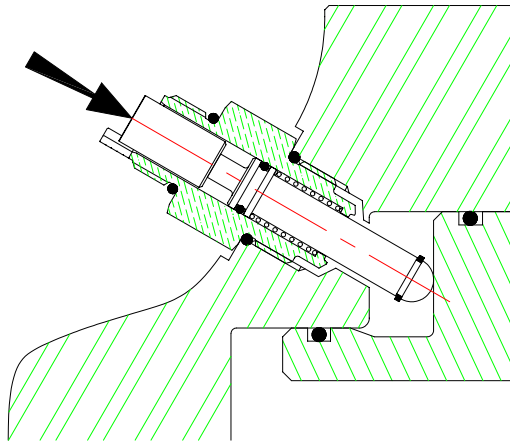

Figure 4

CAUTION

Use of the Birrana brake wear gauge does not eliminate the need to conduct regular braking performance checks, e.g. “drive-through” tests. All manufacturer’s brake inspection and testing procedures, plus any mine specific, regulatory or statutory inspection and testing requirements must continue to be followed.

WARNING

- Ensure the truck park brakes are applied, and chock the truck wheels.
- Isolate and lock-out the truck, in accordance with mine safety procedures.
- Do NOT activate the service brakes or retarder at any point until brake wear measurement has been completed.

1. Remove the cap from the brake wear gauge.

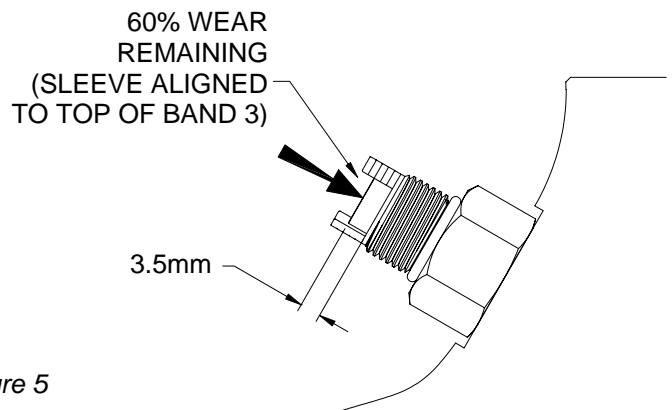
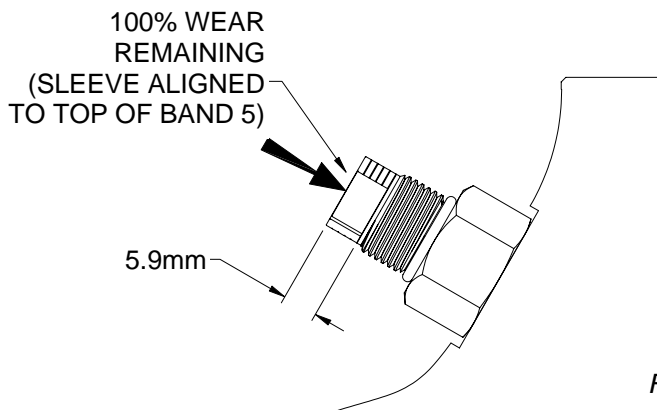

Figure 5

Table 3 – 785 Rear & 793 Front

Percent brake wear remaining	Height from sleeve to bottom of slot	Sleeve aligned to top of band* no.
100%	5.9mm [†]	5
90%	5.3mm	
80%	4.7mm	4
70%	4.1mm	
60%	3.5mm	3
50%	2.9mm	
40%	2.4mm	2
30%	1.8mm	
20%	1.2mm	1
10%	0.6mm	
0%	0.0mm	0

[†]Sleeve flush with top of gauge castellations when new plates are fitted (100% wear remaining).

*Each band corresponds to 20% brake wear. Refer Figure 1 and Figure 5.

2. With the park brakes applied (ie no hydraulic pressure in the park brake release cavity), depress the sleeve to contact the plunger with the brake piston.
3. Take a reading of the wear. This can be done by:
 - a) Measuring the height of the sleeve from the bottom of the slot with a vernier. Refer to Table 3 to determine brake wear.
 - b) Referring to bands on the gauge. If the sleeve is flush with the *bottom* of the castellations, the brake has 0% wear remaining (completely worn). If the sleeve is flush with the *top* of the castellations (aligned to the top of the band 5), the brake has 100% wear remaining (brand new). Refer to Table 3 for more information.
4. Screw on the cap by hand. Do not overtighten.

If you require any further assistance with this procedure please contact your local Birrana representative.
Adelaide (08 8445 7755) Perth (08 9370 5048) Mackay (07 4952 5422) Singleton (02 6571 4488)