

BIRRANA A8640 CONTROL ROD PIN TO SUIT CAT 785/789/793 TRUCKS

ASSEMBLY INSTRUCTIONS

Most accidents involving machine operation or maintenance are caused by failure to observe basic safety rules or safety precautions. Read and understand all safety precautions and warnings, before attempting installation and operation of this component.

Birrana Engineering cannot anticipate every possible circumstance that may involve a potential hazard. You must comply with all mine-specific safety procedures, and satisfy yourself that any procedure, tool or operation method used is safe for yourself and others.

Refer to the truck manufacturer's repair and maintenance instructions in conjunction with these instructions where applicable. Obey all recommended safety instructions or warnings.

Before working on any equipment make sure that the work area is safe, and that the equipment is tagged and locked out in accordance with mine safety procedures.

Note: This instruction is written for pins with three bolts in each end. Earlier pins had one bolt which passed through the length of the pin. Instructions for the earlier pin can be found on Birrana's webpage: www.birrana.com.au

1. Remove the original pin as per manufacturer's instructions.
2. Ensure that the pin components, the chassis and axle housing bores, and the surrounding areas are clean. The chassis and axle housing bores must measure $\varnothing 101.76/101.56$. If the bores do not measure within specification, the bores must be reworked.
3. Assemble the pin through the bearing.
It is essential that an anti-seize compound (ie "Never-seize" or similar product) is used on the collet bores and tapers of the pin.
Do NOT use "Never-seize" on the outside of the collets, or in the chassis and axle housing bores. These surfaces must be clean and dry.
4. Loosely fit the collets to the chassis and axle housing bores. Tap the collets inwards, using a soft-faced hammer to engage the taper on the pin.
5. Apply Loctite 262 to the bolt threads. Install bolts with the shields and washers and tighten finger tight only. DO NOT tighten the bolts at this stage. Keep the pin positioned centrally in the bearing.
6. Tighten the collet bolts evenly and incrementally on each end of the pin in turn to ensure that the pin remains roughly central in the bearing. The final torque should be 220 - 250 Nm (160 - 180 ft lb).
7. Ensure the collets are properly seated by re-torquing the bolts until there is no further collet movement.
8. Fit the grease nipples into the ends of the collets.
9. Use the grease nipples to slowly fill the collets with grease, until the grease can be seen at the locations illustrated.
Note: The purpose of the grease is not to lubricate the pin, but simply to prevent corrosion and make disassembly easier at a later stage.
10. At the next service interval, check the collet bolt torques. If below 220 Nm (160 ft lb), use the procedure in step 6 to re-torque the bolts.

DISASSEMBLY INSTRUCTIONS

Most accidents involving machine operation or maintenance are caused by failure to observe basic safety rules or safety precautions. Read and understand all safety precautions and warnings, before attempting installation and operation of the brake wear gauge.

Birrana Engineering cannot anticipate every possible circumstance that may involve a potential hazard. You must comply with all mine-specific safety procedures, and satisfy yourself that any procedure, tool or operation method used is safe for yourself and others.

Refer to the truck manufacturer's repair and maintenance instructions in conjunction with these instructions where applicable. Obey all recommended safety instructions or warnings.

Before working on any equipment make sure that the work area is safe, and that the equipment is tagged and locked out in accordance with mine safety procedures.

Note: If the collets are undamaged, they may be used again. However, it is advisable that they are replaced with new ones. The old bolts should not be reused and should always be replaced with a new bolts.

1. Undo the 6 off 5/8" bolts (a 15/16" A/F or 24mm socket can be used), and remove them from the collets.
2. Use the three 5/8" UNF jacking holes to extract one collet from it's bore.
3. Using the jacking holes, extract the remaining collet from it's bore.
4. If not previously removed, remove the pin.
5. Remove the control rod assembly as per manufacturer's instructions.
6. If the second collet was not successfully removed previously, and the collet is to be replaced, it can now be removed with a soft drift.

Note: If when attempting to remove the collet, the pin moves instead of the collet, remove the pin. If the existing collets are to be reused, the second collet can then be left in it's bore.

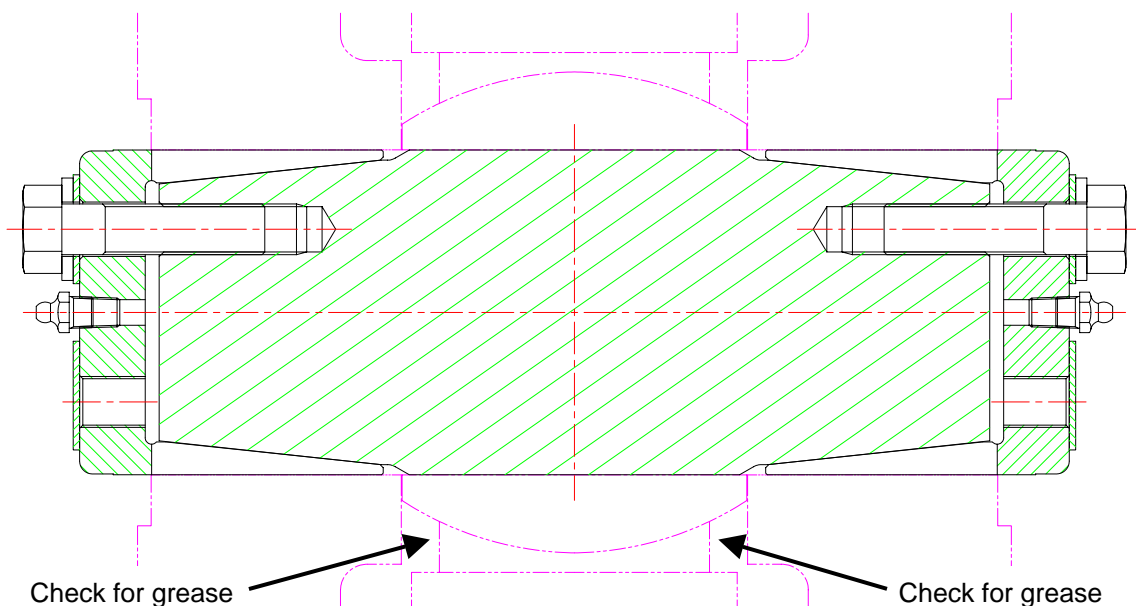

*If you require any further assistance with this procedure please contact your local Birrana representative.
Adelaide (08 8445 7755) Perth (08 9370 5048) Mackay (07 4952 5422) Singleton (02 6571 4488)*